

Rev.	Description	Initiator	Date
01	Initial Drawing	JMW	02/07/2014

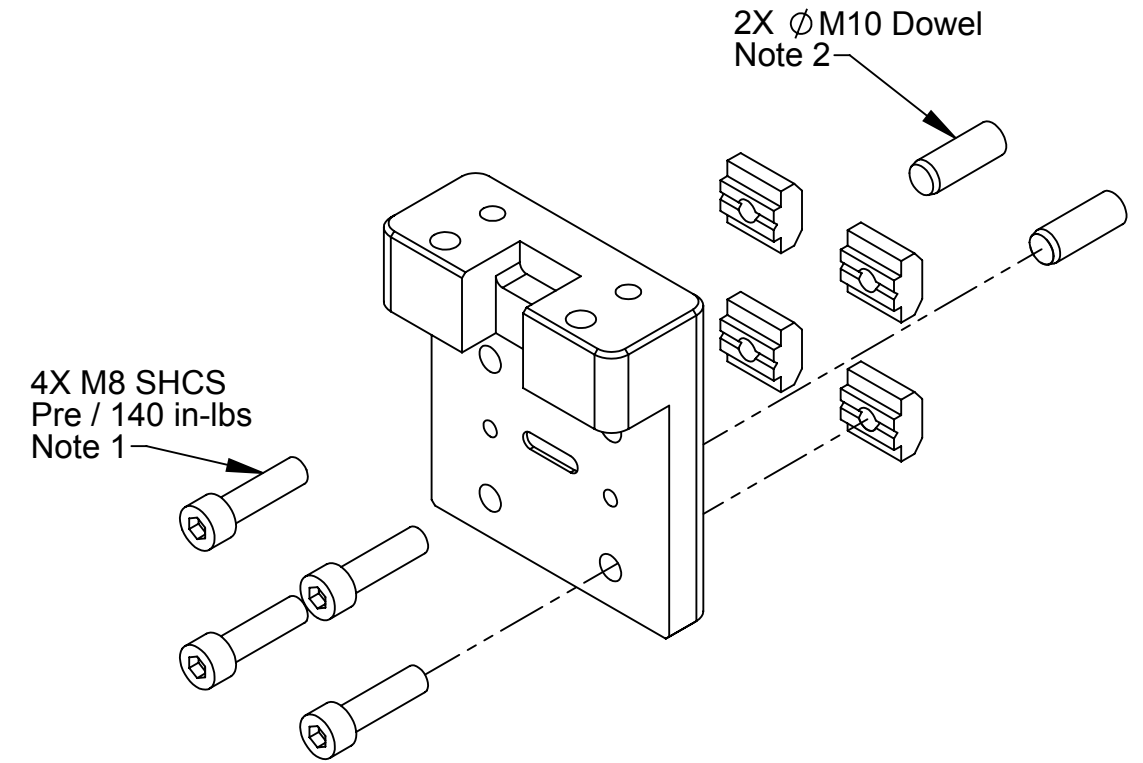
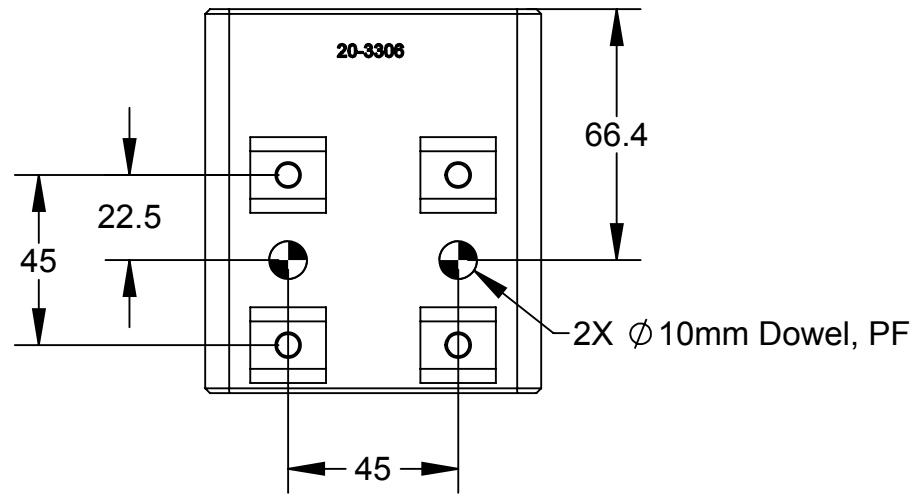
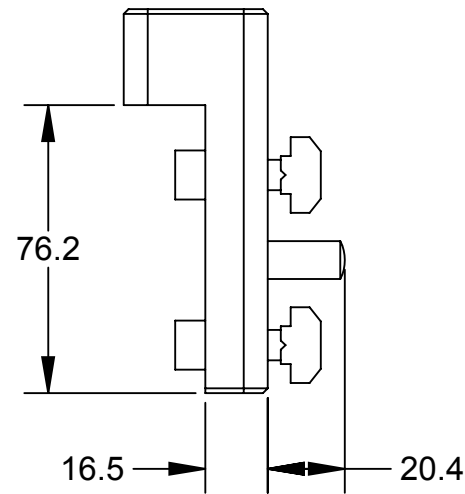
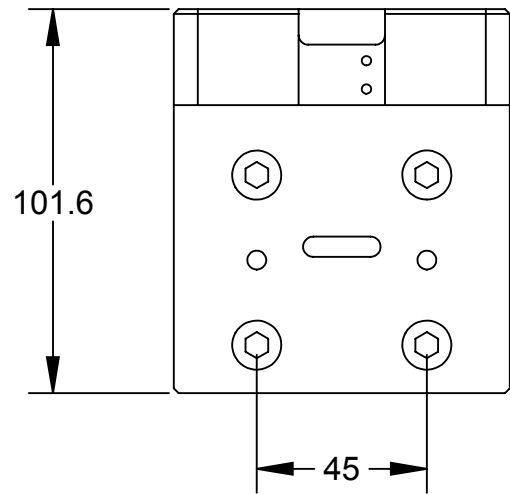
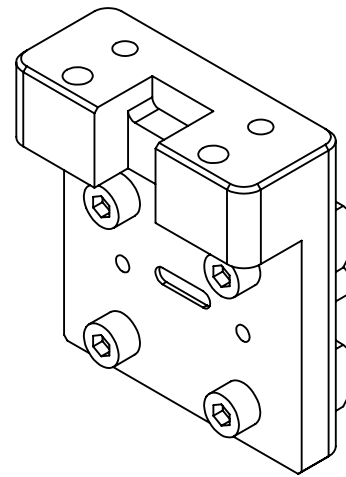
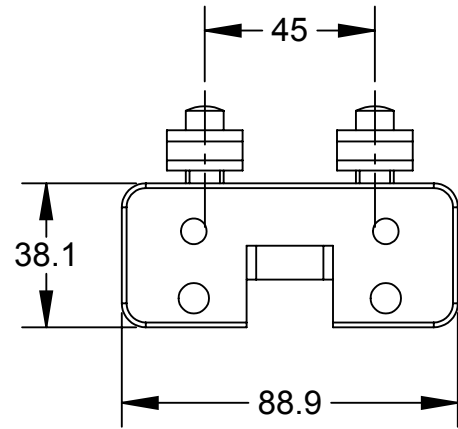

Notes:

1. Customer to install pre-applied fasteners and torque to listed torque value.
2. Customer to install dowels if needed.

NOTES: UNLESS OTHERWISE SPECIFIED.

DO NOT SCALE DRAWING. ALL DIMENSIONS ARE IN MILLIMETERS.



3rd ANGLE PROJECTION

ITEM NO.	QTY.	PART NUMBER	DESCRIPTION
1	1	9120-TSS-MMA-3306	Mounting Module Assembly



**ATI INDUSTRIAL
AUTOMATION**

1031 Goodworth Drive, Apex, NC 27539, USA
 Tel: +1.919.772.0115 Email: info@ati-ia.com
 Fax: +1.919.772.8259 www.ati-ia.com
 ISO 9001 Registered Company

PROPERTY OF ATI INDUSTRIAL AUTOMATION, INC. NOT TO BE REPRODUCED IN ANY MANNER EXCEPT ON ORDER OR WITH PRIOR WRITTEN AUTHORIZATION OF ATI.

DRAWN BY: J. Winterroth, 2/07/14		TITLE	
CHECKED BY: D. Norton, 2/10/14		Mounting Module Assembly	
PROJECT # -	SHEET 1 OF 1	SCALE	SIZE
		1:2	B
		DRAWING NUMBER	REVISION
		9630-20-TSS-MMA-3306	01